

VHF/UHF Yagi Construction

An alternative method for building isolated element Yagi antennas

My first venture into the world of VHF antennas was the construction of a 6-element Optimized Wide-Band (OWA) 2m Yagi¹. I was so pleased with the results that I built two more for the 1.25m and 70cm bands. These three antennas plus a 6m Moxon form the heart of my portable contesting array.

All antenna elements are made from 1/4-inch diameter aluminum rod and are isolated from the boom using tubing clamps. The clamps are bolted to a one-inch square aluminum boom, and a bracket mounted SO-239 connects the driven elements to the coax. All components are commercially available from several sources and no special tools or machining is required. The resulting antenna models have an average free-space gain of 10.2 dbi and 25 dB F/B ratio with a direct 50-ohm feed. The same construction technique is applicable for builders interested in higher gains (i.e. more elements) than those provided by the 6-element versions.

Element Clamps

Many Yagi designs call for custom machined insulators to isolate the element from the boom, and unless the builder owns a machine lathe this presents a problem. To simplify construction, appropriately sized tubing clamps hold and isolate the elements below the boom. These *Vibration Damping Clamps*² are intended to secure and dampen vibration in industrial tubing runs. The same clamp, available from DX Engineering, is referred to as a *Resin Support Block*³. The smallest size available is 1/4-inch diameter and this dictated the standard 1/4-inch element size. Be sure to order the clamps for tubing sizes, not pipe sizes.

Elements

The elements are made from commonly available 6061 aluminum rod. I cut the rod slightly oversize and then trim to length with a stationary disc sander or file. Mark the element center and 1/2 the width of the tubing clamp to allow the element to be centered.

Boom

Cut the 1-inch square aluminum tubing (1/8-inch wall) to length and file the rough edges smooth. Mark the centerline down the length of the boom and then mark the centerlines of the elements. The tubing clamp mounting hole dimension is 0.784 inches - not an easy number to find on a ruler. I print full size templates, cut them out and stick them to the boom marks using a glue stick. Next, center-punch the holes and drill 0.201-inch holes through both sides of the square tubing. Tap the holes with a 1/4-20 tap and wrench. Use stainless steel 1/4-20 cap screws and lock washers to secure the clamps to the boom.

Horizontal polarization allows a shorter boom length because the mast can be attached in the center of the boom without interfering with the antenna's pattern. This assumes that the mast is metallic (non-metallic masts will have no effect on the antenna pattern). For vertical polarization, the boom to mast junction is at the reflector end of the antenna and the boom should be made longer to space it from the mast.

Feedpoint

A 1-3/8 inch length of square boom tubing is used to fabricate the feedpoint bracket. Use a band saw or hack saw to cut away two sides to form a 1x1 inch L shape as viewed from the end. One leg is then cut 3/8 inch wide. File all rough edges and drill mounting holes for the SO-239 connector on the 1-3/8 inch leg. Drill a 0.149 inch diameter hole on the other leg, 3/16 inch from the end. Mount the connector on the bracket and then place the bracket over the driven element tubing blocks. Line up bracket so that the 0.149 inch hole is over the center of one driven element and the SO-239 centerline is lined up over the other driven element. Clamp the bracket in position and drill through the 0.149 inch hole using a 0.106 inch diameter bit into the tubing support bracket and through the driven element. Tap the hole with a 6-32 tap.

Mast-to-Boom Clamp

I experimented with several designs for the mast-to-boom clamp and discovered that Arrow Antennas⁴ sells a neat little bracket for a modest price. The clamp fits mast diameters up to 1-1/2 inch and is made for one-inch square booms.

Conclusion

These modest sized 6-element Yagis are perfect for my portable station as they combine light weight with decent gain. Where applicable, the 1/4-inch OD elements have been optimized from W4RNL's original designs using HAMCALC to ensure that the gain, passband, and front-to-back ratio meet the criteria for a wide band Yagi antenna.

Allen Baker, KG4JJH
211 Brochardt Blvd.
Knoxville, TN 37934
kg4jjh@arrl.net
Home: (865) 675-1915

1. "Notes on 6-Element Wide-Band 2-Meter Yagis", L.B. Cebik, W4RNL;
<http://www.cebik.com/vhf/32m.html>
2. Vibration Damping Clamps, McMaster-Carr; <http://www.mcmaster.com/>
3. Resin Support Block Saddle Clamps, DX Engineering;
<http://www.dxengineering.com/Products.asp?ID=24&SecID=1&DeptID=33>
4. Mounting Bracket, model# M/B, Arrow Antennas, <http://arrowantennas.com/>

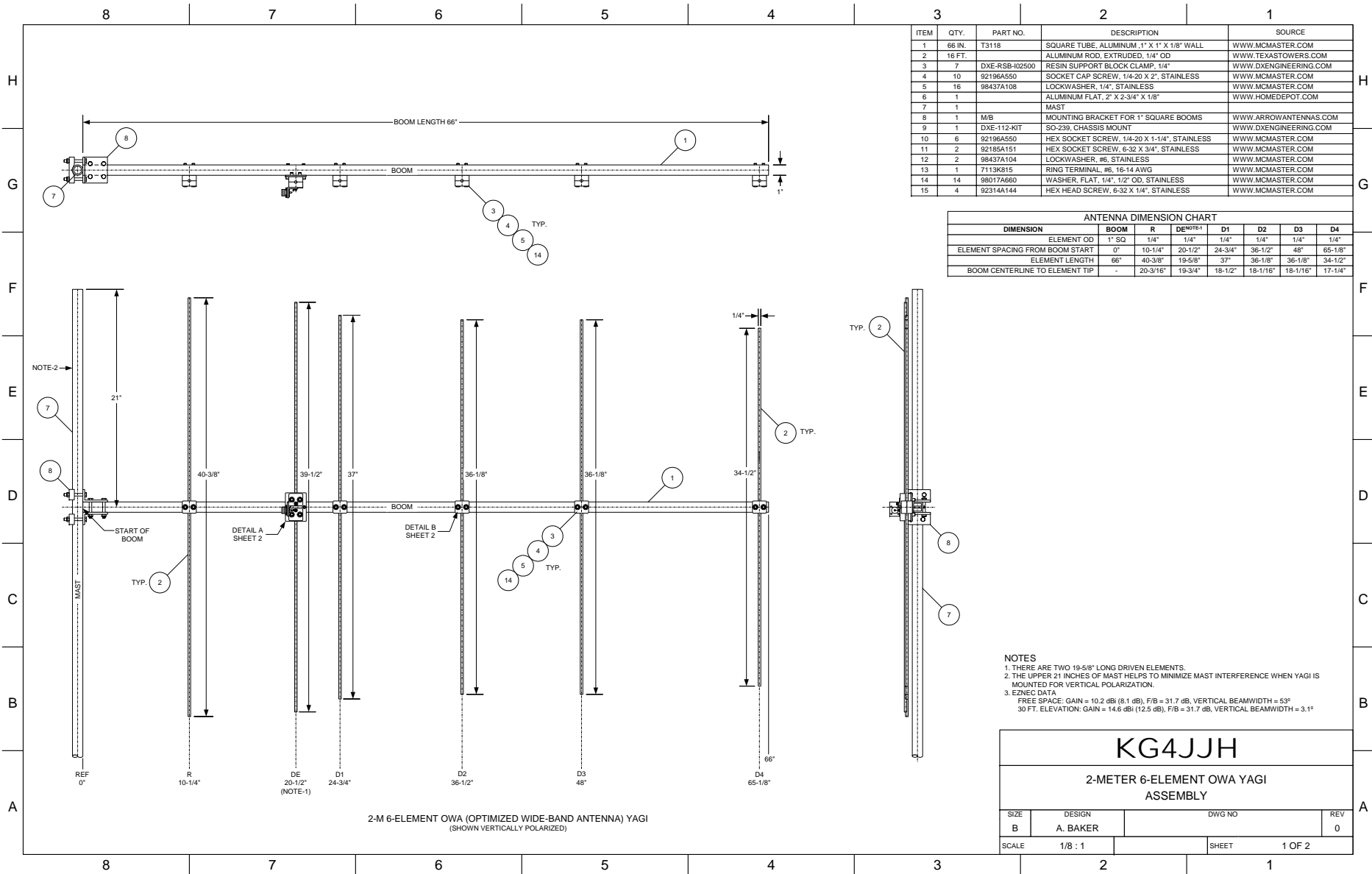

- NOTES**
1. THERE ARE TWO 19-5/8" LONG DRIVEN ELEMENTS.
 2. THE UPPER 21 INCHES OF MAST HELPS TO MINIMIZE MAST INTERFERENCE WHEN YAGI IS MOUNTED FOR VERTICAL POLARIZATION.
 3. EZNEC DATA
 FREE SPACE: GAIN = 10.2 dB (8.1 dB), F/B = 31.7 dB, VERTICAL BEAMWIDTH = 53°
 30 FT. ELEVATION: GAIN = 14.6 dB (12.5 dB), F/B = 31.7 dB, VERTICAL BEAMWIDTH = 3.1°

KG4JJH			
2-METER 6-ELEMENT OWA YAGI ASSEMBLY			
SIZE	DESIGN	DWG NO	REV
B	A. BAKER		0
SCALE	1/8" : 1	SHEET	1 OF 2

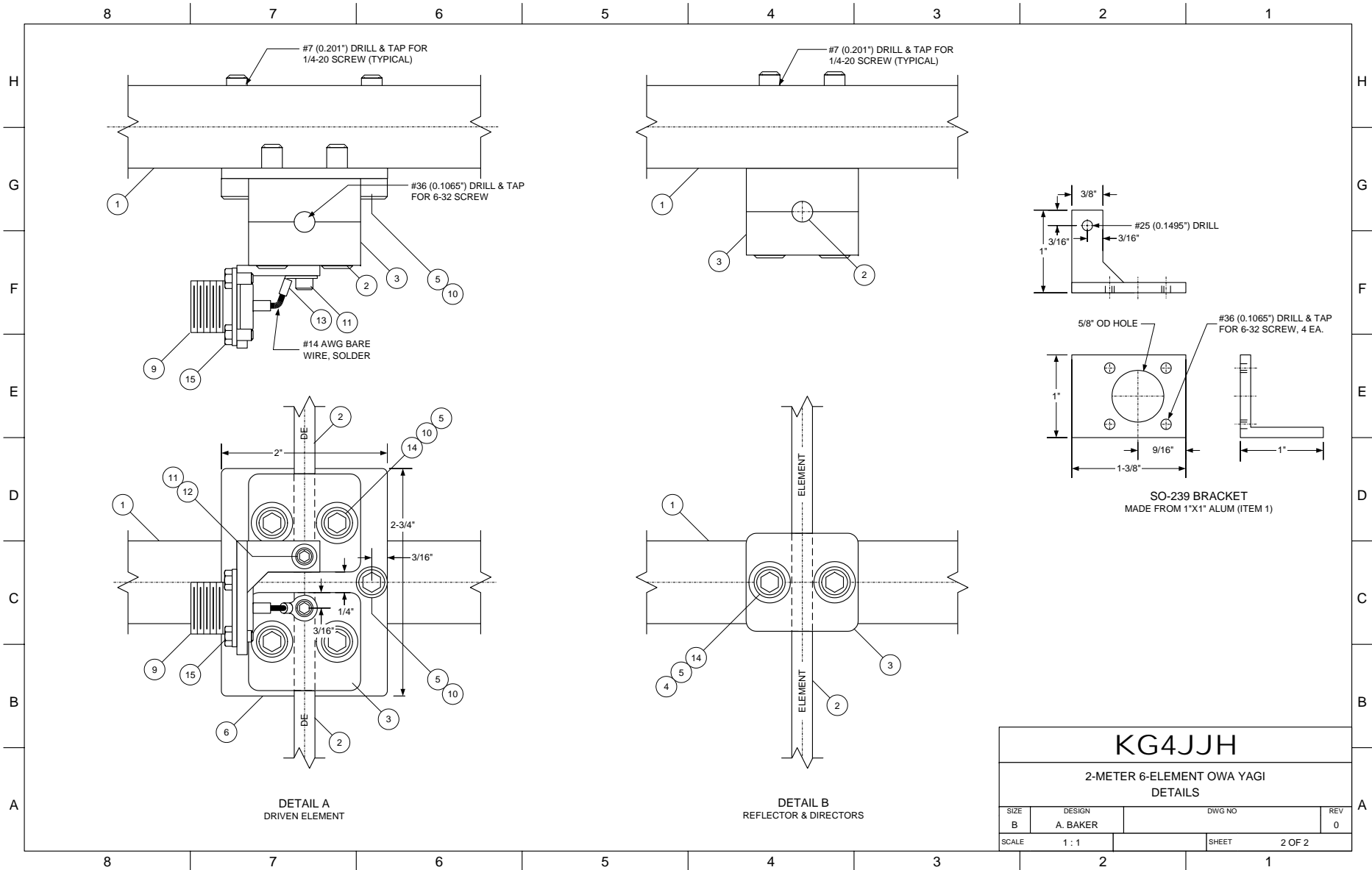

DETAIL A
DRIVEN ELEMENT

DETAIL B
REFLECTOR & DIRECTORS

KG4JJH

2-METER 6-ELEMENT OWA YAGI DETAILS

SIZE B	DESIGN A. BAKER	DWG NO	REV 0
SCALE 1 : 1		SHEET 2 OF 2	

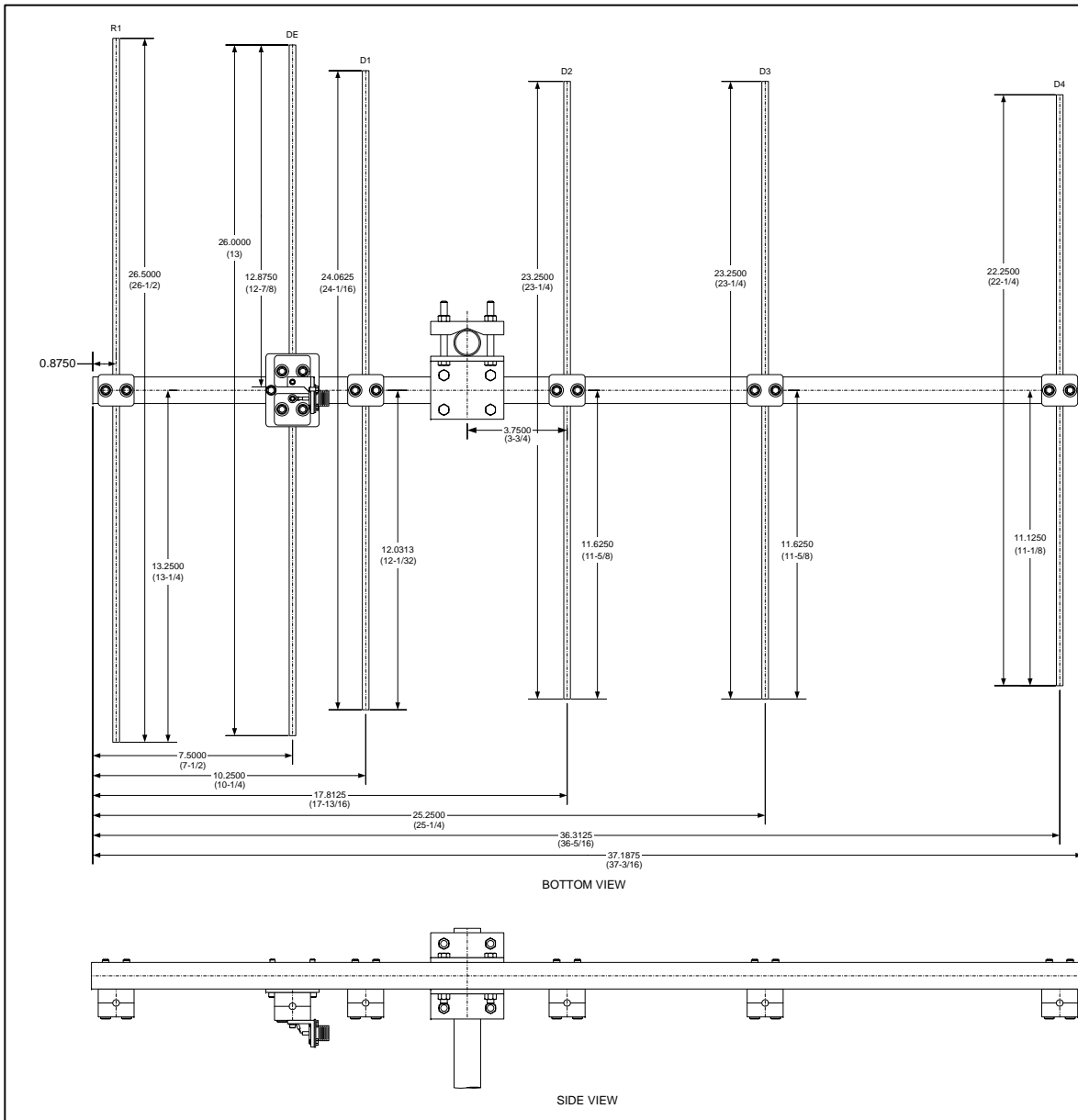

ITEM	QTY	PART NO.	DESCRIPTION	SOURCE
1	37-1/4"	88875K33	SQUARE TUBE, ALUMINUM, 1" X 1" X 1/8" WALL	MCMASTER.COM
2	3	8974K31	ALUMINUM ROD, EXTRUDED, 1/4" OD, 6 FT.	MCMASTER.COM
3	7	DXE-RSB-102500	RESIN SUPPORT BLOCK CLAMP, 1/4"	DXENGINEERING.COM
4	14	92196A50	SOCKET CAP SCREW, 1/4-20 X 2", STAINLESS	MCMASTER.COM
5	14	98437A110	LOCKWASHER, 1/4", STAINLESS	MCMASTER.COM
6	1		ALUMINUM FLAT, 2" X 2-3/4" X 1/8"	HOMEDEPOT.COM
7	1	M/B	MOUNTING BRACKET FOR 1" SQUARE BOOMS	ARROWANTENNAS.COM
8	6	92196A544	HEX SOCKET SCREW, 1/4-20 X 1-1/4", STAINLESS	MCMASTER.COM
9	2	92196A150	HEX SOCKET SCREW, 6-32 X 5/8", STAINLESS	MCMASTER.COM
10	2	98437A104	LOCKWASHER, #6, STAINLESS	MCMASTER.COM
11	2	7113K815	RING TERMINAL, #6, 16-14 AWG	MCMASTER.COM

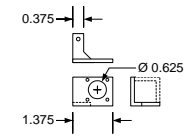

KG4JJH		
1.25M, 6 EL, OWA YAGI ASSEMBLY		
SCALE: 1/4:1	SHEET 1 OF 2	REV. 0

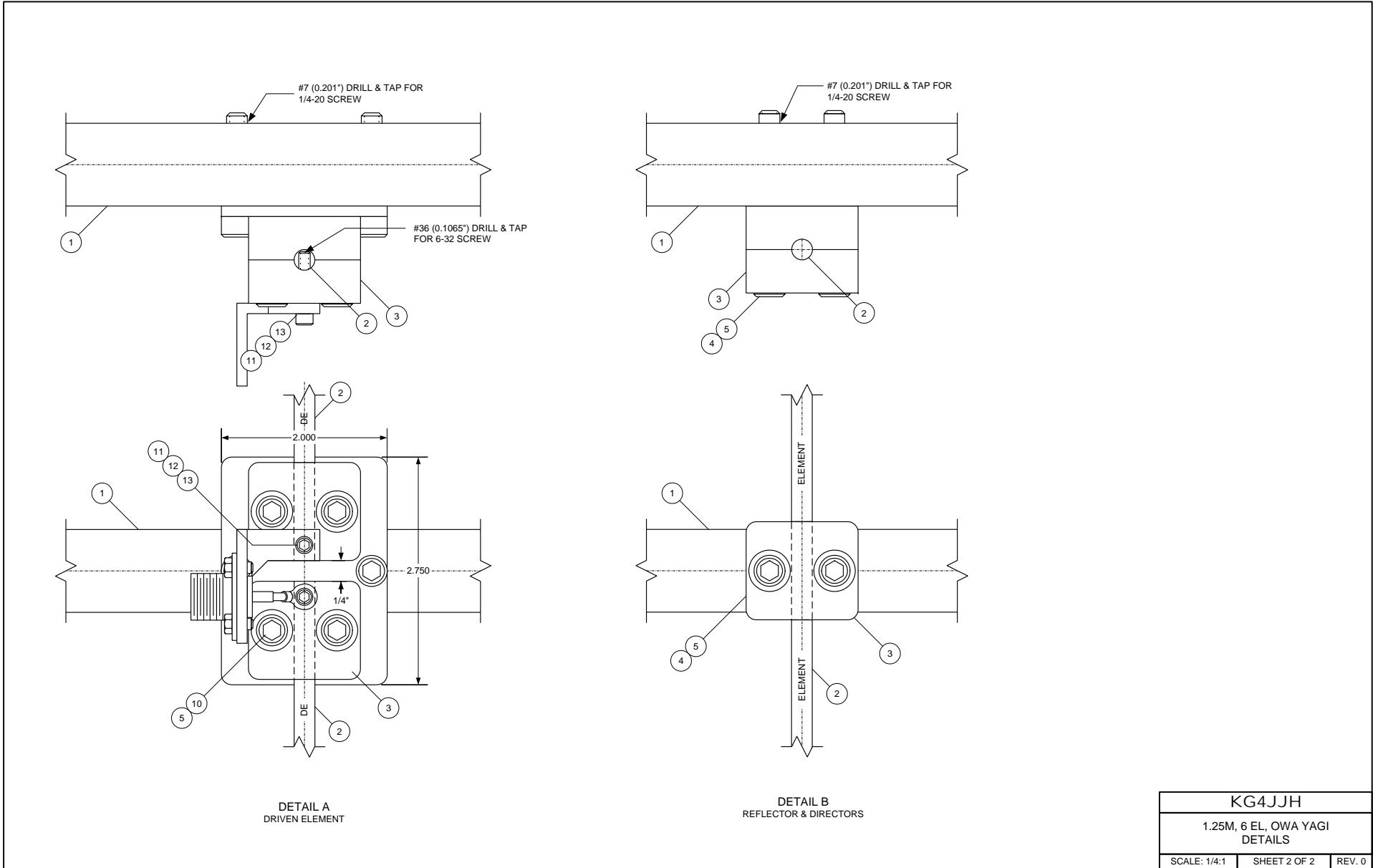

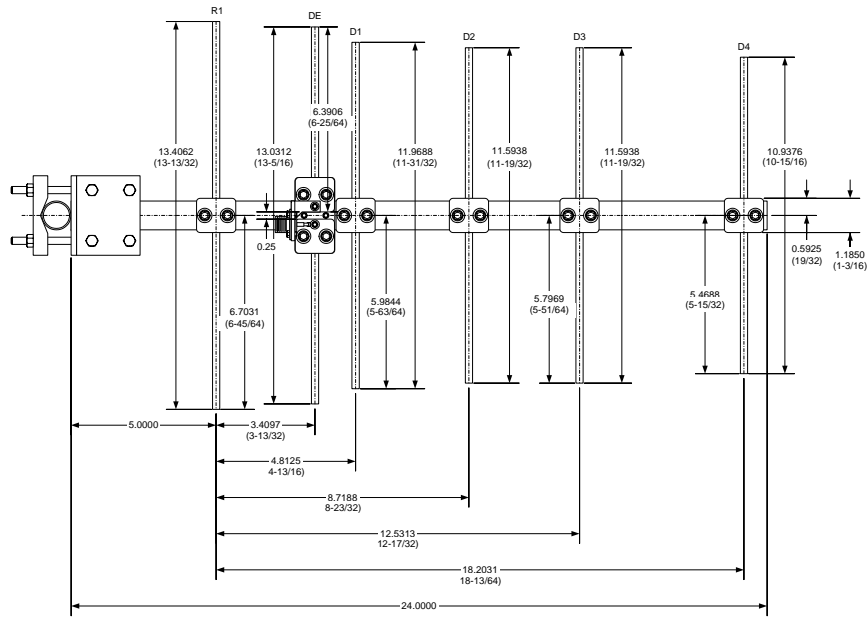

BOTTOM VIEW

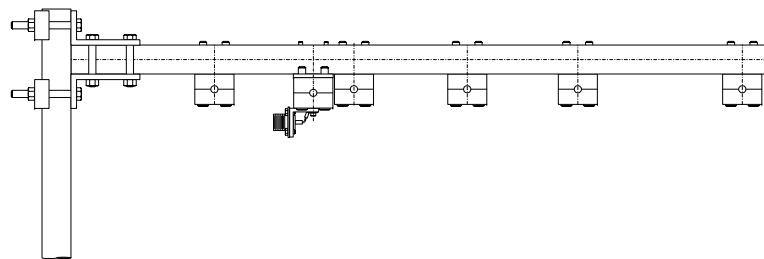

SIDE VIEW

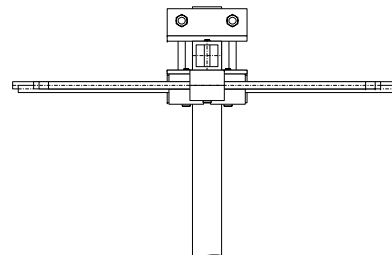

END VIEW

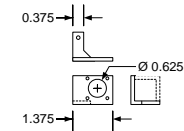

ITEM	QTY	PART NO.	DESCRIPTION	SOURCE
1	24 IN.	T3118	SQUARE TUBE, ALUMINUM, 1" X 1" X 1/8" WALL	WWW.MCMASTER.COM
2	7 FT.		ALUMINUM ROD, EXTRUDED, 1/4" OD	WWW.TEXASTOWERS.COM
3	7	DXE-RSB-02500	RESIN SUPPORT BLOCK CLAMP, 1/4"	WWW.DXENGINEERING.COM
4	14	92196A279	SOCKET CAP SCREW, 1/4-20 X 2", STAINLESS	WWW.MCMASTER.COM
5	14	98437A110	LOCKWASHER, 1/4, STAINLESS	WWW.MCMASTER.COM
6	1		ALUMINUM FLAT, 1-3/8" X 2-5/8" X 1/8"	WWW.HOMEDEPOT.COM
7	1		MAST, 1" TO 1-1/2" OD, ALUMINUM	WWW.TEXASTOWERS.COM
8	1	MB	MOUNTING BRACKET FOR 1" SQUARE BOOMS	WWW.ARROWANTENNAS.COM
9	6	92196A201	HEX SOCKET SCREW, 8-32 X 1-1/4", STAINLESS	WWW.MCMASTER.COM
10	2	92196A150	HEX SOCKET SCREW, 8-32 X 5/8", STAINLESS	WWW.MCMASTER.COM
11	2	98437A104	LOCKWASHER, #6, STAINLESS	WWW.MCMASTER.COM
12	2	7113K815	RING TERMINAL, #6, 16-14 AWG	WWW.MCMASTER.COM

- NOTES
 1. THERE ARE TWO 6-25/64" LONG DRIVEN ELEMENTS.
 2. EZNEC DATA:
 F0 = 438MHz
 FREE SPACE: GAIN = 10.22 dBi (8.1 dB), F/B = 29.5 dB
 30 FT. ELEVATION: GAIN = 16.14 dBi (12.5 dB), F/B = 29.5 dB

KG4JJH		
70 CM, 6 EL, OWA YAGI ASSEMBLY		
SCALE: 1/4:1	SHEET 1 OF 2	REV. 0

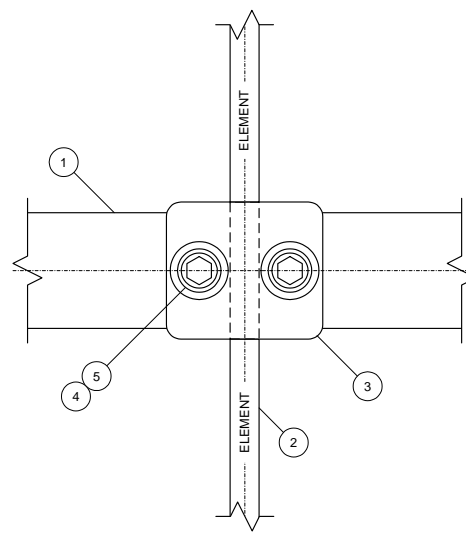
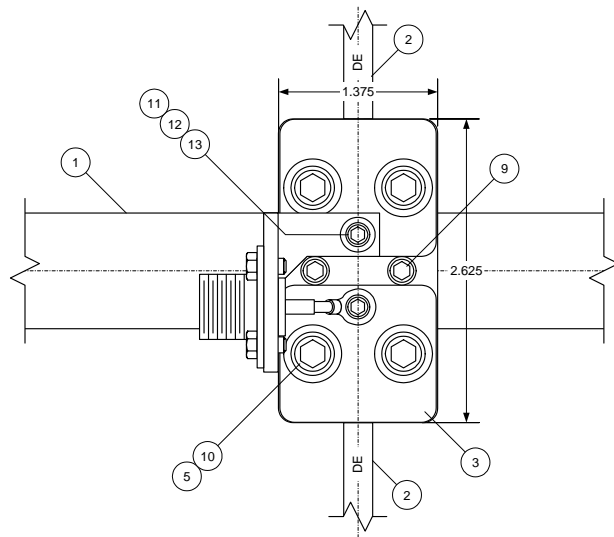
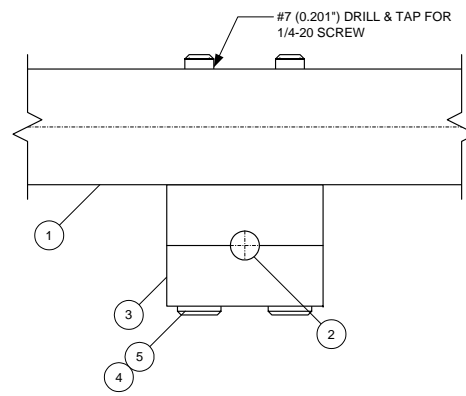
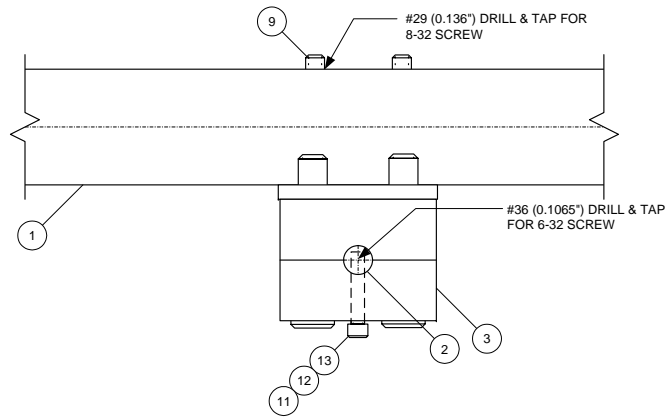

DETAIL A
DRIVEN ELEMENT

DETAIL B
REFLECTOR & DIRECTORS

KG4JJH		
70 CM, 6 EL, OWA YAGI ASSEMBLY		
SCALE: 1/4:1	SHEET 2 OF 2	REV. 0